

Integrated GIS Work Environment With ESRI Products

Author: Kapil Chhabra

Co-Author: Puneet Sharma

Abstract

The family of ESRI products offers a range of flexible functionality for GIS data development, data update, temporal data maintenance, and enhancements using specialized conflation functionalities. It provides work environment integration between in-office and out-field automations through effective utilization of map objects for developing custom edit stations and wide area connectivity using Arc-SDE and Arc-IMS. It facilitates developers to build software with custom user interfaces from cartographically styled geo-databases, and dynamic attribute displays using feature linked annotation functionality of Arc GIS.

This paper describes extensive utilization of ESRI products to create a seamless work environment, for managing the entire work cycle of GIS data, empowered with the flexible integrations using VBA, Arc Objects, Map Objects, VC++ and java components. Map Objects based user applications on Laptops help create a perfect environment for GIS data development / update and field data collection / verification, and finally providing informative cartographically styled outputs.

Introduction

Rapid developments in computer technology and information dissemination technologies, and the increasing accessibility to spatial information sources are all converging to provide a new impetus to "Geographical Information Systems. The increased use of GIS for business decision-making processes has made it imperative for GI solution providers to be in sync with technological advances. These developments have created a need for an integrated work environment, so that various GIS data cycles can all interface into a common platform. After a detailed study of the various competing platforms, ESRI range of products was identified as meeting most of the requirements.

GIS Data Cycle

The GIS Data has its own cyclic data flow sequencing, a unique inter-dependency relationship, and a repetitive reoccurrence due to the temporal nature of the data. The GIS data cycle can largely be defined in the following broad categories:

- a) GIS Data Development (in-office)
- b) GIS Data Collation (out-office/field data collection / verification)
- c) GIS Data Update (and enhancements)
- d) GIS Data Usage (visualization / analysis / componentization / presentation)

GIS Data Development (in-office) starts with conceptualizing the business needs and defining the modeling specifications. GIS data development includes creation and modeling of a digital format data, which can be related to a space on the globe and can represent the spatial features of that space, derived from a collection of input datasets.

GIS Data Collation (out-office/field data collection / verification) is a continuous process built with the objective of keeping the primary data of an organization as updated as possible, with on-site surveys and data sanity checks, and at the same time track for the temporal changes.

GIS Data Update (and enhancements) can be a complete data update or a change only update depending on how the data is structured at the supplier's end.

GIS Data Usage (visualization / analysis / componentization / presentation) includes customized displays, shown online or on-screen or on specialized paper maps designed for providing adequate information to the user.

Integrated Work Environment With ESRI Products

Integrating the work environment, largely centered on a given family of products, enabled:

- Seamless workflows across the various GIS data cycles
- Data inter-operability across various stages / cycles
- Development of re-usable components
- Focused expertise: generating effective processes and innovative solutions

The continuous use of ESRI products across various GIS data cycles can be elucidated through the below mentioned case study of a live project carried out by RMSI:

Land Parcel Information System (LPIS): depicting the GIS data flow through creation, field verifications, updating and presentation etc.

Land Parcel Information System (LPIS)

Background

In the year 2001, our client a governmental agency, in UK, responsible for agriculture and rural affairs, took an initiative to adopt the latest practices in digital mapping technology. The project was aimed at improving the client's GI database so that it could effectively manage the subsidy payments to farmers under various schemes in vogue.

As part of the European Commission's **Common Agricultural Policy (CAP)** dealing with arable and forage lands, a control system was introduced in 1992, known as the **Integrated Administration and Control System (IACS)**. IACS is an annual declaration of all land farmed for the respective claim year and supporting information, which includes, for example, each parcel size and crop grown.

This EU requirement presented a major challenge for the client, as it needed to convert all IACS land data, numbering over 500,000 IACS land parcel center points, involving more than 17,000 farmer holdings, into a digital GIS format with spatial boundaries. Ownership changes, shared claims on land and conflicting farm boundaries made this project even more critical and challenging.

The project deliverables included spatial parcel database of half a million parcels, created with the aid of Ordnance Survey landline data and aerial photographs, and the paper plots for the 17,000 holdings. The data finalization phase included updating the digital datasets for the additional inputs received from the client through their on-site farm inspections and interviews with farmers.

GIS Data Development (stage-1), comprised of digital capturing of the farm parcels for the entire region, with the help of Ordnance Survey landline plus data, aerial photographs, farmers claims and some historic digital parcel data.

GIS Data Collation (stage-2), carried out by the client, included validation of stage-1 outputs through on-site verification and face-to-face interviews with the farmers, and on the spot marking of changes to parcels.

GIS Data Update (stage-3), involved integrating the outcome of the field verifications, into the central data server. The central data server became very efficient, as the filed data collation was made digital, so that the field staff could actually provide 'almost true' replica of the changes required and the changes could be tracked well.

GIS Data Usage (stage-4) comprised of presenting the finalized digital dataset in the form of paper plots, with the captured farm parcels overlaid on the imagery, holding by holding, for a final sign-off.

The Project Phase

The first step for GIS data development (i.e. creation) involved putting together a team of GIS professionals with expertise in large and complex data conversion projects, conceptualization and process / system developments.

The project conceptualization, implementation, execution, and sign-off processes are shown below, as applicable, through the various GIS data cycles discussed earlier in this paper.

GIS Data Development (in-office) - The Digital Editing System (DES)

To enable effective data capturing, with varied inputs, a custom **Data Editing System (DES)** was built with ESRI Map-Objects as the front-end and SQL database using an in-house geo-database concept (without the SDE interface), as the backend. The DES allowed information of various types like aerial photographs, OS Landline, previous year's parcel layer and other reference layers to be seen together with the current year's parcel layer. It also provided the requisite functionalities needed for the data editing process. The data capture was followed by a series of quality checks, both manual and automated for enabling error free outputs.



Data Editing System

An automated plotting system was also designed, where a holding's parcels could be plotted using set templates into a PDF document. This PDF could then be easily sent via email to various offices of the client for checking and verification of farm parcel boundaries.

Data Collation Phase - The Digital Markup Unit (DMU)

The client had targeted to meet each holding's owner over a period of six months, to validate the field boundaries that were created during stage-1. This validation was planned to be undertaken using paper maps of the holdings, on which interviewers would mark changes by colored pencils, after consulting the farmer. The client undertook three pilots in the beginning of 2002 to assess the feasibility of field verifications and realized the massive efforts required to do correctives on the paper plots and the associated complexity of transferring those changes back into the digital dataset.

As an outcome of the learnings from the pilot projects, a joint team deliberated on the alternatives and proposed the development of a laptop-based solution. RMSI prototyped a Map-Objects based system and demonstrated the concept. The client liked the concept and agreed to fund the development of a **Digital Mark-up Unit (DMU)**.

The DMU had the requisite functionality to enable marking up of the changes in the field and had built-in data validations to prevent erroneous marking right at the time of interviews. The editing functions, as provided, are illustrated below:

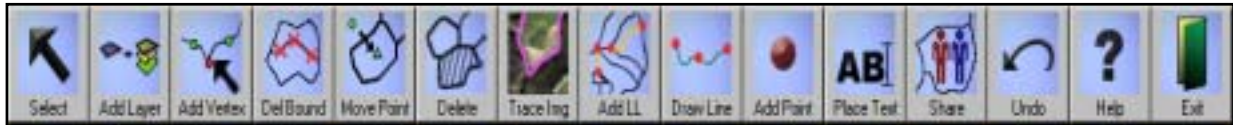

Digital Mark-up Unit: The data editing toolbar

The client used the DMU successfully from June 2002 to April 2003, to send these digital markups to the project execution team for changes to be implemented into the LPIS layer. The project team completed all such edits, by the end of April 2003 and submitted the land parcel layer back to the client.

GIS Data Update: WISARD (An Information System For Agricultural And Rural Data)

The success of the DES and the DMU in transforming the process in which the farm parcel layer was created for the client gave further impetus to the vision of a digitally enabled future. The system conceptualized for enterprise wide implementation was to enable collection, distribution and management of GI data, for a wide variety of agricultural land based activities that the client undertakes.

Thus evolved the concept of the 'Enhanced Digital Mark-up Unit' (EDMU), a better-structured and more powerful version of the DMU that would be central to all spatial data operations and be generic enough to create and edit different subsidy schemes operated by the client. The Enhanced DMU would be able to access datasets like OS

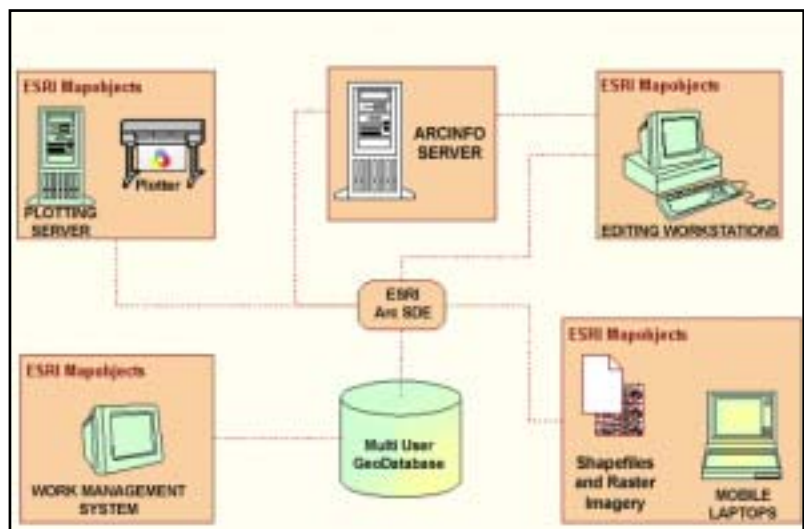

WISARD: System

Master map, common land datasets etc., in addition to its existing capability of accessing on the fly aerial photography and paper raster maps etc.

EDMU enabled collection and dissemination of spatial data from the field to the office where actual decision-making took place. The system also provided image capture and voice recording facilities so that the farmer can convey as much information as possible to the central editing team. Some of the key components of the WISARD system were:

- a) **A Scheme Builder**, a system by which the client could create and manage the spatial data specifications of various schemes that are used in the EDMU. Scheme builder made the WISARD system generic by allowing super-users the freedom to create a scheme and define relevant attributes.
- b) **Data Exchange Mechanisms**, the land parcel layer consisting of the parcel polygons and relevant attributes needed to be as current as possible for all business uses within various departments of the client, across the region. The WISARD system allowed on-line and off-line update

of the land parcel layer in local and divisional offices, and provided facility to transfer the digital markups from divisional offices to the central editing team.

The entire network architecture was a three-tier structure (see picture below) with the first tier being represented by the central GI team at the main office. The second tier being represented by the divisional offices, connected via WAN to the main office. The third tier being represented by the various local offices, field inspector and FM (W) officer teams, who are not connected to the server directly and have to send the data through offline means.

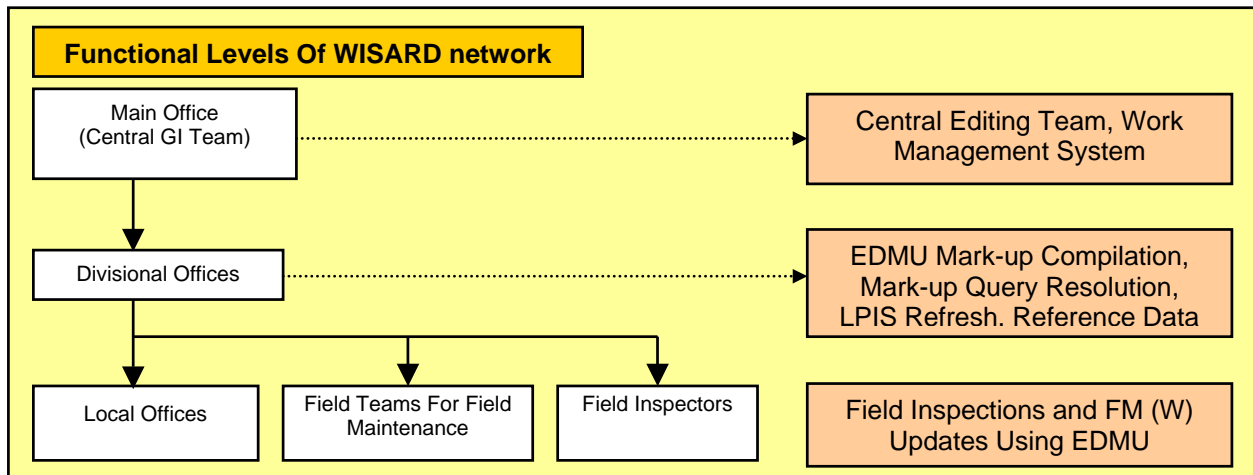

WISARD: Network Architecture

The WISARD system stored the entire Master-Map data, in a SDE server and provisions were made for effortless updates of the Master-Map as and when the Ordnance Survey creates positional improvements for the same. The Work Management System provided functionalities to manage this seemingly difficult transfer of various datasets across the region.

c) A customized **Land Parcel Editing System** had been created on Map-Objects front-end, with Arc-SDE / SQL backend having easy to use and robust editing features. The system was completely tailor-made for the client and integrated within itself extensive business rules of client's operations. The editing system provided facilities like importing master-map, creating thematic, displaying aerial images, editing attributes, creating comments to be sent to divisional offices besides having a host of topological editing features.

The history viewer facility in the editing environment was another unique feature, built on archiving protocols, to allow the client to view the historical shape and attributes of a parcel. The editing system accessed OS Master-map data through SDE server and had multiple layers available for reference to the user. The Work Management System guided the entire work allocation and submission by the users. The user just has to press allocate on his desktop to allow the system to

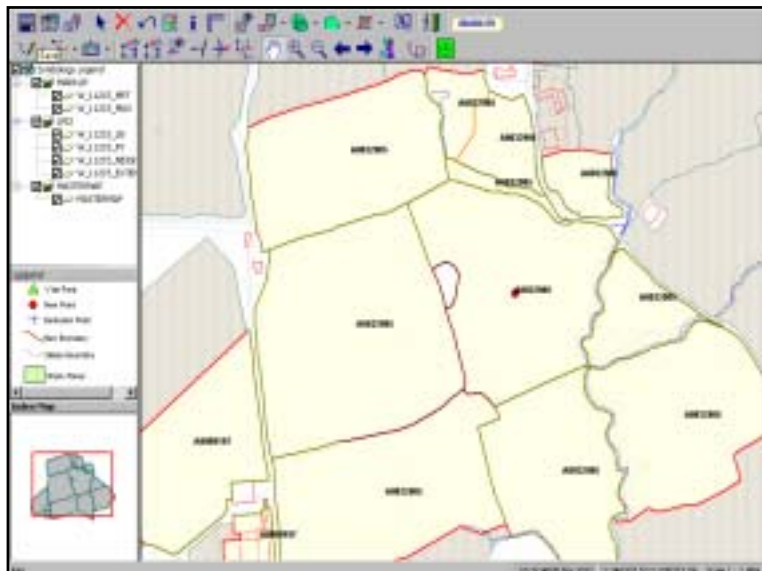

WISARD: Data Editing System

allocate the highest priority work to the user. The editing system builds into itself a series of automated validations during submission to prevent any erroneous data to get into the central database in SDE.

d) **Work Management System**, created for WISARD was the backbone of the information system, and was used for project monitoring, user performance statistics, priority management, inventory control and status reports, thus ensuring smooth and transparent project coordination. It also provided features to enable interchange of information between the client and other related organizations,



Work Management System

which manages the administration of CAP schemes. The Work Management System had extensive features for database health checks and provided up to date status regarding integrity of the data. The WMS was customized to allow the administrator the flexibility to create and assign work to specific users or rest easy by letting the system automatically allocate work on the basis of pre-defined priority. The WMS was built using Map-Objects with integrity checks running on Arc-Info, and SQL Database.

Data Usage Phase – The WISARD Plotting Engine

An automated plotting system was created in addition to the UI which could be used to query / display parcel data for creating customized plots of farmer's holdings. The plotting system enabled single/batch plotting in different templates like pre inspection, post-inspection, post FM (W) etc. and created easy to view PDF for farmer parcels. The plotting system was highly generic and could be customized by changing SQL database tables. The plotting system used smart custom labeling options along with multiple business rules during the creation of data tables and was built on ESRI Map-Objects. Aerial photographs were stored in JPG format and the background landline data was stored for relevant layers. Rendering of the land parcels was done so that individual layers depicted on the plot were clearly distinguishable to the user. The plotting engine also had an optimization algorithm developed so that a holding lying over a large area could be plotted using the minimum number of paper sheets.

Partners In Development

The development of WISARD project had been a team effort, a team consisting of the system designers, programmers and project managers from the consortium end, and also a large number of focused groups pulled together within the GI services division of the client. The client had been organizing workshops and meetings between user-groups and ILR from the time of the implementation of the DMU, much before the WISARD system was conceptualized.

The relationship shared between the partners in the project and the client was far from a client – vendor relationship. It was that of a team player, based on trust and even the tricky issues were sorted out in an amicable manner. The credit for this goes to none other than the innovative senior team members at the client end, who were able to successfully balance the project requirements, project

funding and were able to develop the trust with all players to create this state-of-the-art land parcel information system.

Further Directions

RMSI is in the process of developing another high-end solution for a premier agricultural authority. The solution is similar to the 'Land Management System', as detailed above, and is being developed with a web based front-end. The system called 'Web Enabled Land Management System' is an Intranet/Internet enabled system, allowing update and maintenance of the digital geographic record of the parcels.

The solution is being conceptualized within the overall solution framework proposed by the client and is completely built using Map-Objects for JAVA. The web engine uses Arc-Info as a secure and robust topology engine. The data layer incorporates Arc-SDE and Oracle Spatial database. The GI application has the ability to read and write spatial data and attribute data to the database and uses API's for interacting with other databases stored within the client's overall system.

Author

Kapil Chhabra
General Manager (GIS)
RMSI, A-7, Sector 16
NOIDA 201 301, UP, INDIA
Tel: +91 120 251 1102
Fax: +91 120 251 0963
Email: Kapil.Chhabra@rmsi.com

Co-Author

Puneet Sharma
General Manager (Software)
RMSI, A-7, Sector 16
NOIDA 201 301, UP, INDIA
Tel: +91 120 251 1102
Fax: +91 120 251 0963
Email: Puneet.Sharma@rmsi.com